

We are the ONLY One

Pumpworks Industrial is the only manufacturer of ANSI pumps who provide every Power Frame with all of the following standard features:

- | | |
|---|---|
| <ul style="list-style-type: none"> 1 Carbon steel (WCB) construction 2 Wrought steel mounting foot (Group 2 and above) 3 316L SS shafts (sleeved or solid shaft) 4 Finned frame for lower oil and bearing temperatures 5 Splash oil lubrication 6 Glyptol™ enamel coated power frame interior surface 7 ISOMAG™ magnetic bearing isolators | <ul style="list-style-type: none"> 8 Enlarged oil fill connection 9 Enlarged oil sight glass installed on each side of power frame 10 Thrust bearing housing can only be installed the correct way 11 Available with patented Predict-Plus proactive condition monitoring 12 5-Year Unconditional (no questions asked) power frame warranty 13 5-Year Zero Maintenance power frame (no oil change required) |
|---|---|

Why is PumpWorks the ONLY One?

- | | |
|--|---|
| <ul style="list-style-type: none"> » We are focused on reducing our customers' MRO spend. » We will only provide the very best, common sense, solutions. | <ul style="list-style-type: none"> » We believe the most economical parts you can buy aren't necessarily the ones that you need to buy. » We are customer driven. |
|--|---|

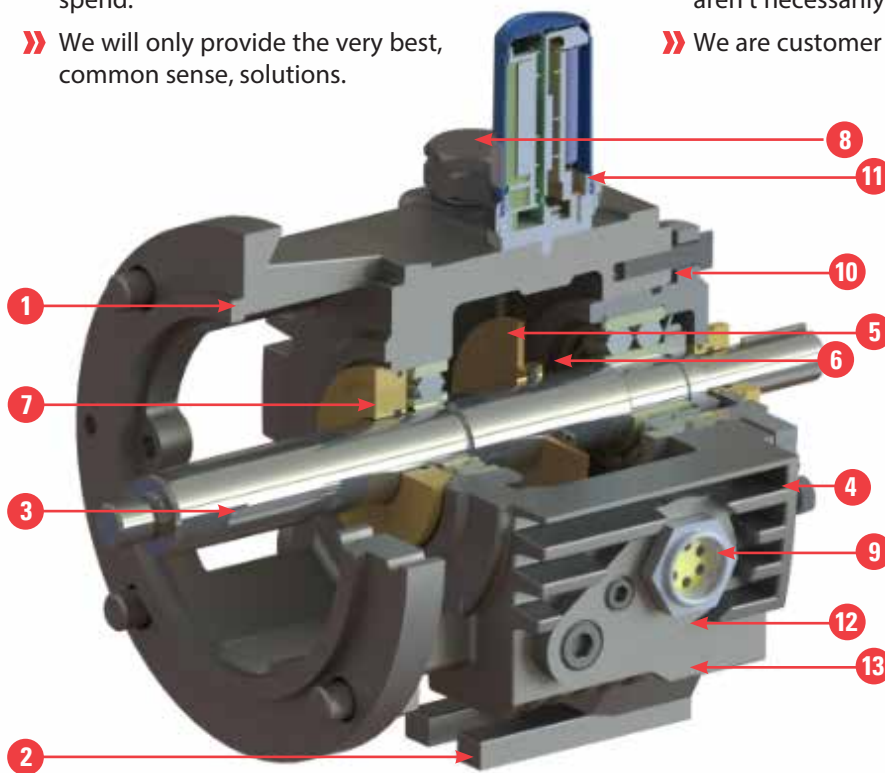

Quality

- » Manufactured and tested in the USA

Delivery

- » Pump components strategically inventoried for rapid shipment in a variety of material options

ePOD Pump Selector

- » Access to end users and specifiers to select your pump application online at www.pumpworks.com